



Where quality becomes beauty



# X MIND unity



## Quality, Design, your image

Because you pay more and more attention to the look and effectiveness of your practice.

ACTEON® SATELEC® has developed X-Mind™ unity with:

- uncompromising design
- clean lines
- proven quality
- superior materials
- unique technological advantages





X MIND  
unity + SOPIX 

The perfect union



X-Mind™ unity is pre-wired to allow for the integration of the SOPIX digital sensor. Therefore, you can simply connect it to your X-Mind™ unity at the time of installation or anytime in the future.



SOPIX inside enables integration without any visible cables. SOPIX inside connects effortlessly to the X-Mind™ unity without technical assistance within a minute. Plug and Play!





## Less radiation

With the ACE technology, patented by SOPRO®, over-exposed images are eliminated.

Regardless of the amount of radiation emitted by the generator, the SOPIX sensor only uses the optimal dose required for a quality image.

This technology applied to X-Mind™ unity allows the SOPIX sensor to start and stop the generator thus avoiding all risk of over exposing the image and patient as well as unnecessary re-takes of acquisitions.

The patient only receives the necessary and adapted dose to his dental morphology.

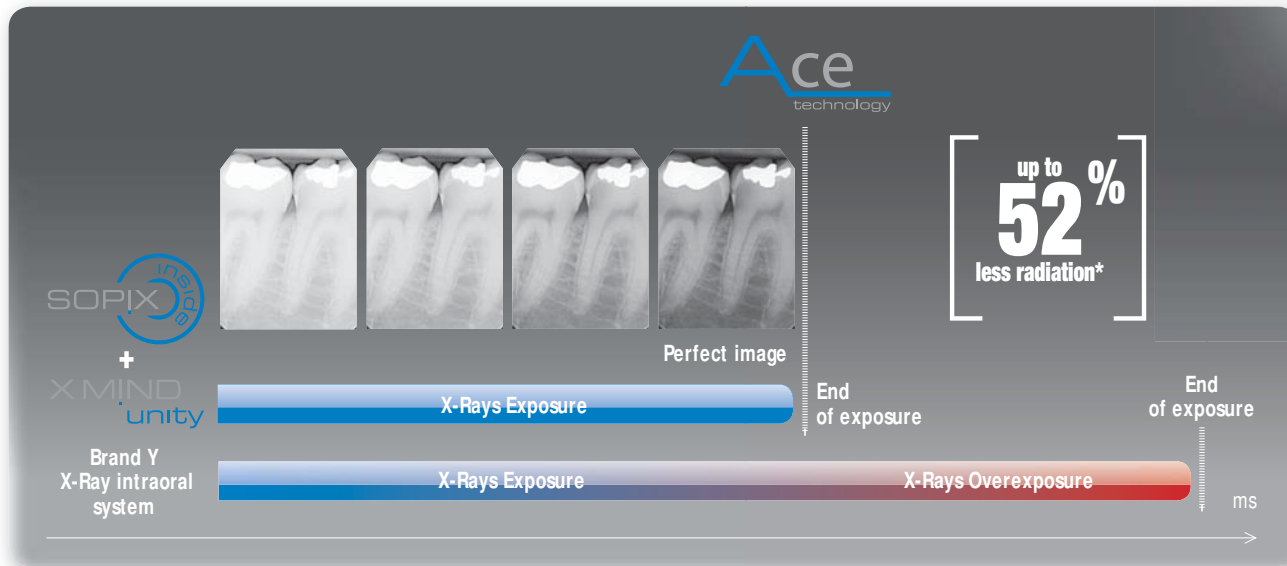
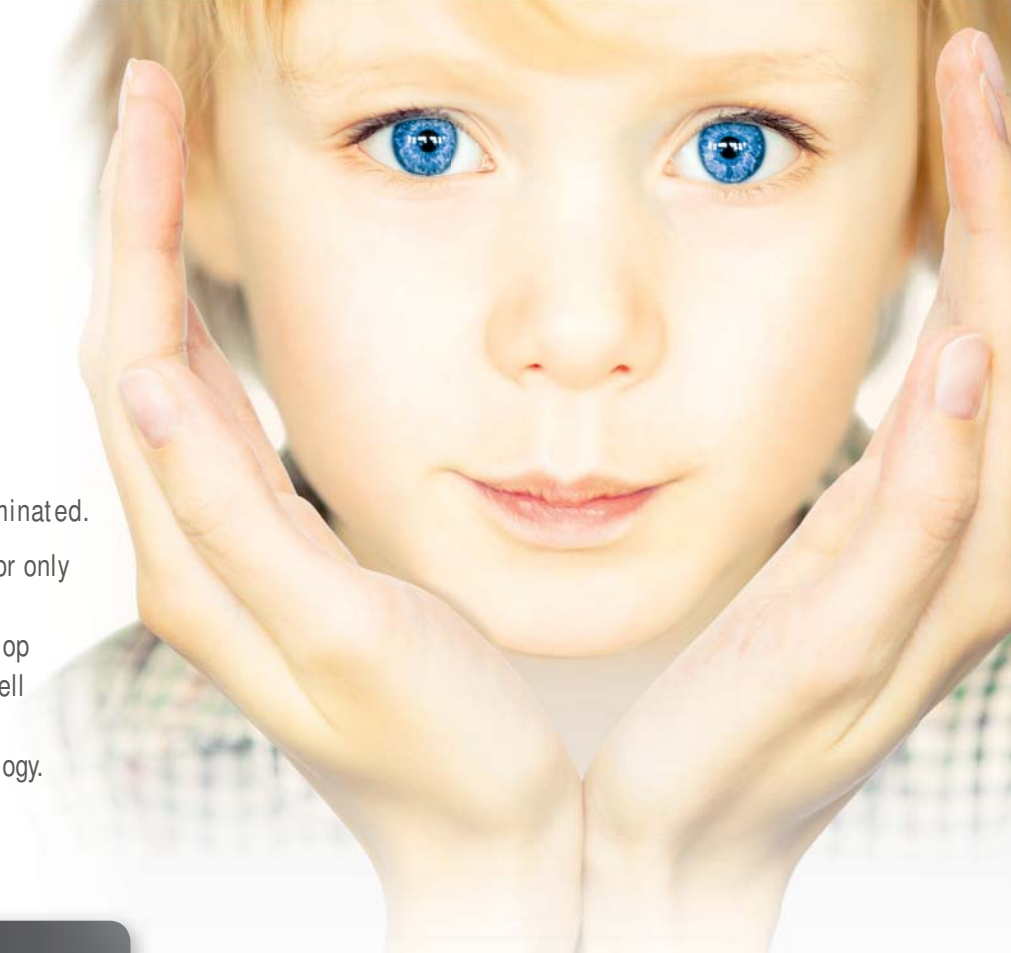

### Traceability.

The dose received by the patient after each exposure appears on the timer's screen.

With SOPIX inside, this dose is also recorded in the patient's file of SOPRO Imaging ensuring permanent traceability.

\* Reduction variable according to the patient's morphology.



## Work comfort

Due to its ergonomically designed holder there is no danger of the sensor falling or breaking and always remains within hands reach for optimal working comfort.

SOPIX inside is internally wired eliminating the need for external wiring: ease of use and aesthetics of your practice.





# X MIND unity

## A sharp and contrasted image

The X-Mind™ unity has a 0.4 mm focal spot.  
It has several configurable radiological settings:

- the anodic voltage (60, 65 and 70 kV)
- the anodic current (from 4 to 7 mA)

These parameters ensure a sharp and contrasted image with defined contours.

The generator focal spot Y:  
0.7 mm



The generator focal spot  
of X-Mind™ unity: 0.4 mm



# X MIND unity

## Fluidity and stability

You can singlehandedly position and stabilize X-Mind™ unity.

Movement is fluid and is done without any effort or stress.

The anti-vibration and anti-movement mechanism ensures drift free positioning during an exposure.





X-MIND  
Unity

# X MIND unity

Ergonomic and simplistic

**THE «MEMORY» FUNCTION** allows modifying  
for the pre-programmed exposure times  
to adapt to the specifications  
of your sensor or film

**THE EXPOSURE PARAMETERS**  
are adjusted according to the type  
of tooth - (incisor, premolar, molar)



→ **A CLEAR AND LARGE LCD SCREEN**

to easily see the main parameters at a distance

→ Displays **THE PARAMETERS** kV, mA, type of film and ACE selection (SOPIX inside)

→ **THE DOSE IS DISPLAYED**

when simultaneously pressing the buttons « - and + »

→ Selection of the **PATIENT MORPHOLOGY** adult, child

→ **SELECTION OF THE EXAM TYPE**

occlusal or inter proximal



Acquiring an X-ray is done with the integrated firing switch. A remote firing switch is available as an option.





# X MIND unity

## More flexibility

The X-Mind™ unity can accommodate any operatory configuration.

3 arm lengths are available: 0.40 m, 0.80 m, 1.10 m and can be top or bottom mounted.

With its adaptable wall plate, it is easy to replace an older generator with the X-Mind™ unity without having to do additional drilling on the wall.

## Technical specifications

Classification.....	Class 1 type B
Supply voltage .....	100-240 V
Maximum power absorption.....	850 VA
X-ray tube .....	TOSHIBA D-041
Frequency.....	50/ 60 Hz
Focal spot .....	0.4 mm
Total filtration .....	>1.5 mm Al @ 70 kV
Leakage radiation .....	< 0,25 mGy / h
Cooling duty cycle for 1 s .....	32 s
Technology .....	High frequency DC
Maximum anode current .....	7 mA
X-ray tube voltage .....	60/ 65/ 70 kV
Maximum exposure time .....	2 s
Compatibility .....	Film, phosphor plate, digital sensor
Weight .....	23 kg
Configuration .....	Wall mounting top and bottom
Timer .....	Microprocessor controlled

## Accessories

Circular cone Ø 60 mm.....	20 cm (8") or 30 cm (12")
Rectangular cone 45 x 36 mm.....	30 cm (12")
Arm extension .....	0.40 m, 0.80 m, 1.10 m
SOPIX inside/ SOPIX <sup>2</sup> inside.....	Size 1, size 2
Adaptable mounting wall plate	
Remote exposure switch	

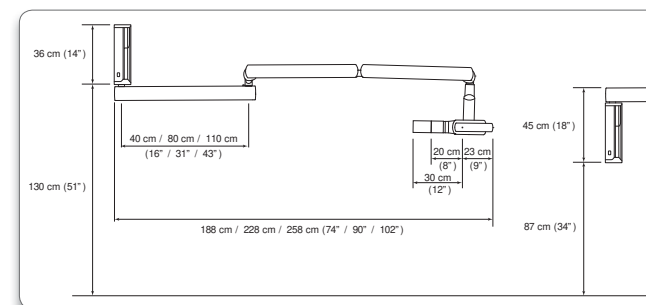
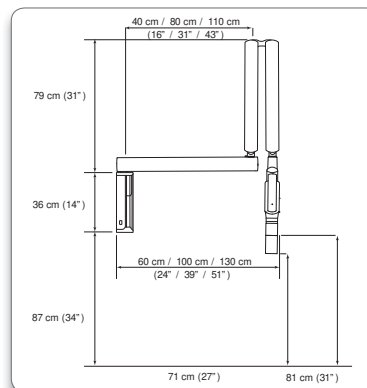
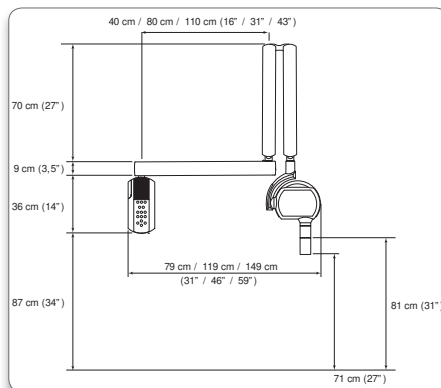

Manufactured in compliance with currently applicable regulations and standards (EC Directive 93/ 42/ EEC and sub-segment amendment).  
IEC 60601-2-65 imposes for each x-ray generator furnished with a digital sensor to use a square cone.